

**RESTRICTED**

**PILOT'S HANDBOOK  
FOR  
STEARMAN AIRPLANES  
MODELS N2S-1, N2S-2, AND N2S-3**

**REPORT NO. A75NI-9001**

**JANUARY 20, 1941**

**MANUFACTURED FOR  
UNITED STATES NAVY DEPARTMENT  
BUREAU OF AERONAUTICS**

**RELEASED BY THE BUREAU OF AERONAUTICS  
NAVY DEPARTMENT**

**COMPILED BY  
STEARMAN AIRCRAFT  
DIVISION OF BOEING AIRPLANE COMPANY  
WICHITA, KANSAS**

"THE LOCKER PROVIDED FOR CLASSIFIED DATA IN THIS AIRPLANE GIVES CLASS 'C' STOWAGE AS DEFINED BY ARTICLE 112 of R.P.S.-6".

SECTION I

A - TABLE OF CONTENTS

<u>Section</u>	<u>Page</u>
I	
A - Table of Contents . . . . .	1
B - List of Illustrations . . . . .	2
C - Foreword. . . . .	3
D - Table of Characteristics. . . . .	7
II	
<u>COCKPIT ARRANGEMENT AND CONTROLS</u>	
A - Cockpit Arrangement . . . . .	8
B - Flying Controls . . . . .	8
C - Power Plant Controls. . . . .	17-18
D - Auxiliary Controls. . . . .	19-21
III	
<u>POWER PLANT OPERATION</u>	
A - General Data. . . . .	22
B - Rating. . . . .	22
C - Starting. . . . .	23
D - Warm-up . . . . .	23
E - Stopping. . . . .	23-24
F - Mixture Control . . . . .	24
G - Fuel. . . . .	24
H - Oil . . . . .	24
I - Overspeed . . . . .	24
J - Fuel System . . . . .	24-26
K - Oil System. . . . .	26
L - Carburetor Air Heat Control . . . . .	30
M - Fuel Consumption. . . . .	30-31
IV	
NORMAL INSTRUMENT READINGS. . . . .	32
V	
<u>FLYING CHARACTERISTICS</u>	
A - Balance . . . . .	33
B - Useful Load . . . . .	33
C - Take-off. . . . .	33
D - Maneuvers . . . . .	34
E - Maneuvers Prohibited. . . . .	34
VI	
TAXYING . . . . .	35

## B - ILLUSTRATIONS

<u>Figure</u>		<u>Page</u>
1	Model N2S-1 - Left Side . . . . .	4
2	Model N2S-2 - Left Side . . . . .	5
3	Model N2S-3 - Left Side . . . . .	6
4	Model N2S-1 - Front Cockpit - Right Side . . . . .	9
5	Model N2S-1 - Front Cockpit - Left Side . . . . .	10
6	Model N2S-1 - Rear Cockpit - Right Side . . . . .	11
7	Model N2S-1 - Rear Cockpit - Left Side . . . . .	12
8	Models N2S-2 and N2S-3 - Front Cockpit - Right Side	13
9	Models N2S-2 and N2S-3 - Front Cockpit - Left Side.	14
10	Models N2S-2 and N2S-3 - Rear Cockpit - Right Side.	15
11	Models N2S-2 and N2S-3 - Rear Cockpit - Left Side .	16.
12	Model N2S-1, N2S-2 and N2S-3 - Fuel System. . . . .	25
13	Model N2S-1 - Oil System. . . . .	27
14	Model N2S-2 - Oil System. . . . .	28
15	Model N2S-3 - Oil System. . . . .	29
16	Curve - Brake Horsepower vs. Altitude (R-680-8 Lycoming Engine) . . . . .	36
17	Curve - Brake Horsepower vs. Absolute Mean Pressure (R-680-8 Lycoming Engine). . . . .	37
18	Curve - Brake Horsepower vs. Altitude (R-670-4 Continental Engine). . . . .	38
19	Curve - Brake Horsepower vs. Absolute Mean Pressure (R-670-4 Continental Engine) . . . . .	39

## SECTION I

### C - FORWARD

The purpose of this Handbook is to give the pilot a complete understanding of the operation and flying characteristics of the Model N2S-1, N2S-2 and N2S-3 airplanes in the most condensed form. Care has been taken to preserve this unity of purpose throughout the entire Handbook so that any single item, or group of items, may be quickly and easily utilized by the pilot.

The reading matter has been reduced to the bare essentials of vital information and the whole book indexed so that the pilot may readily obtain the maximum information about the entire airplane, or any part of it, in the least possible time and with the least possible reading effort.

Any further information required relative to these airplanes and not given in this Pilot's Handbook may be found in the Erection and Maintenance Manual stowed in the Data Case fastened to the lid of the baggage compartment.

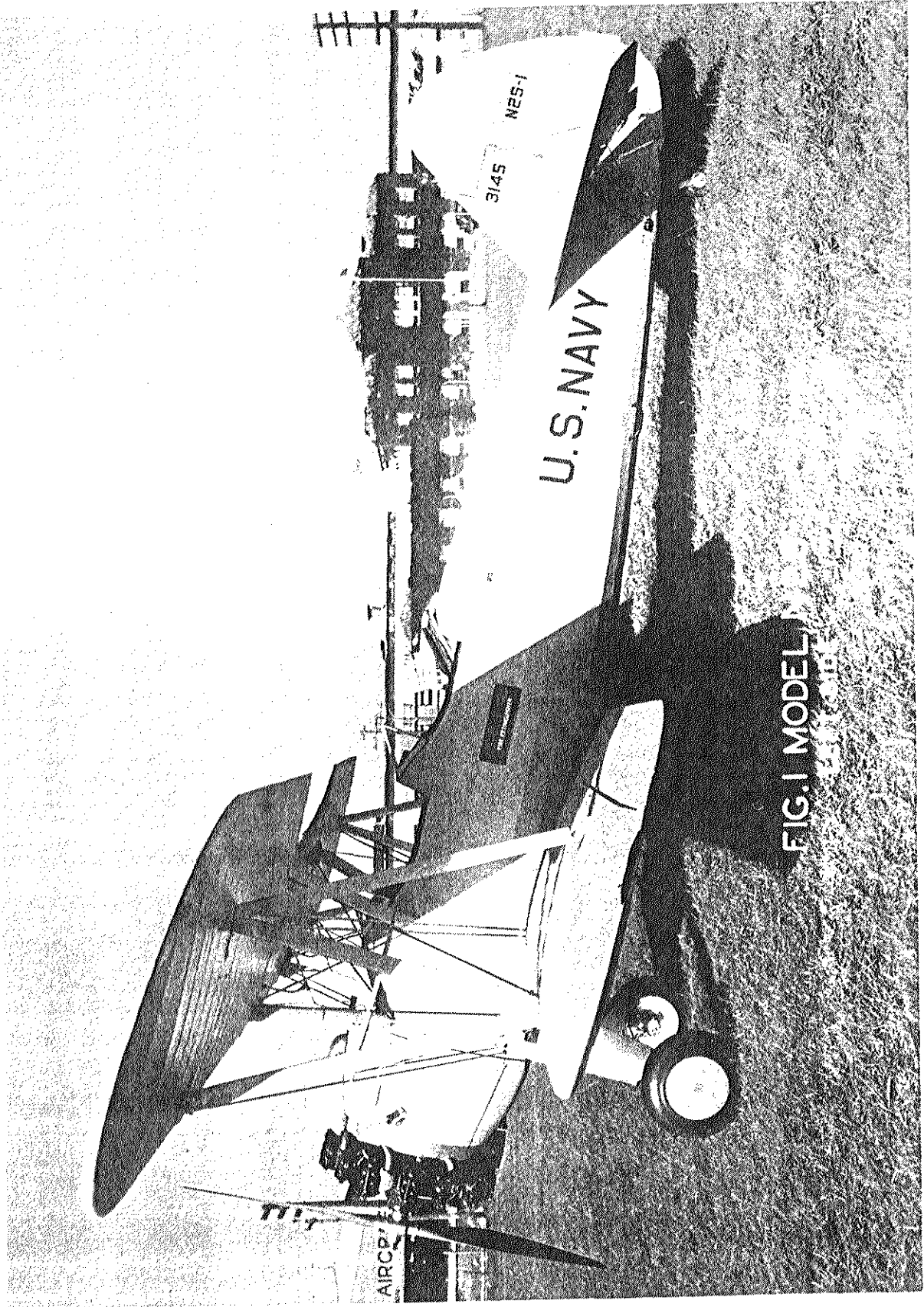
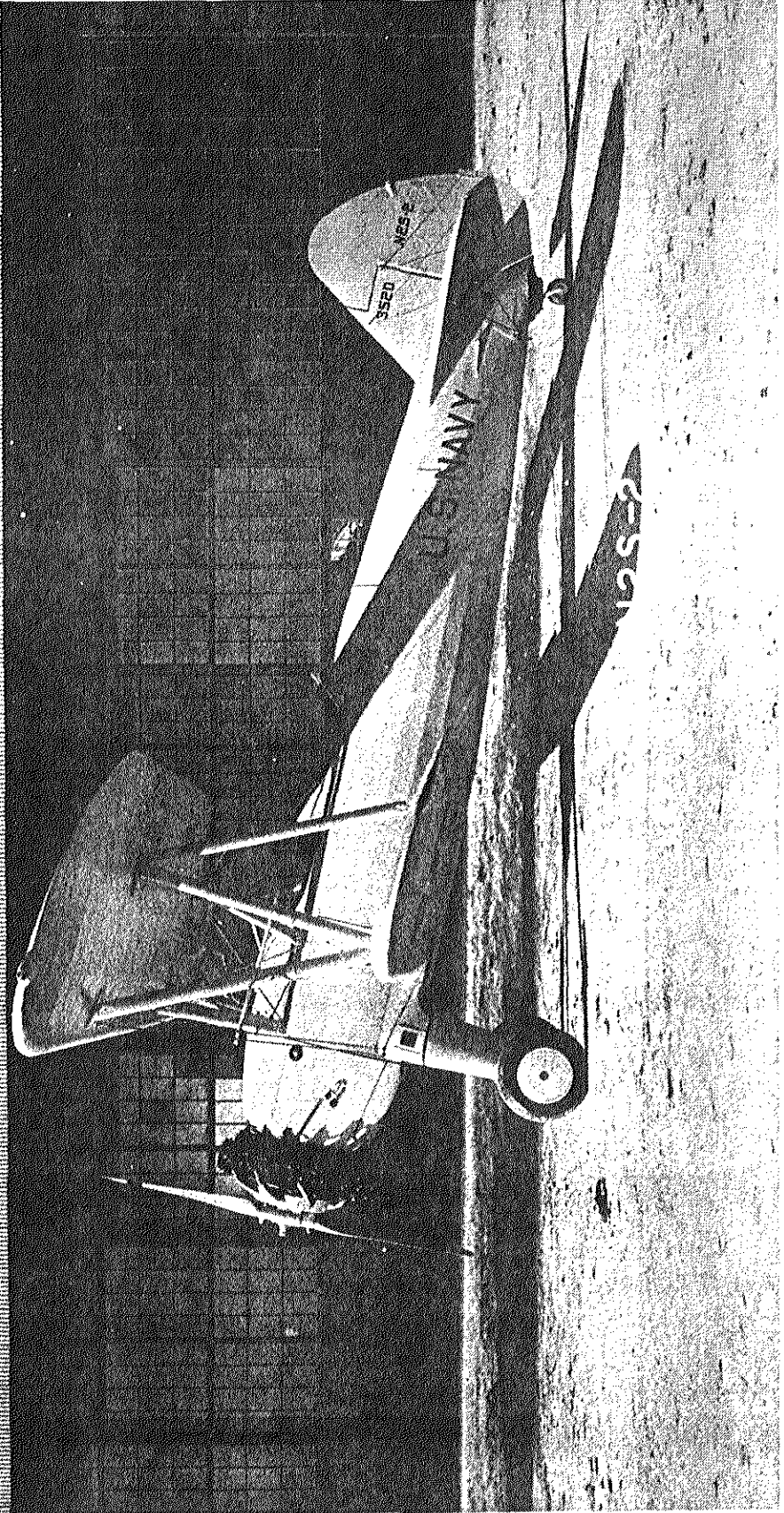
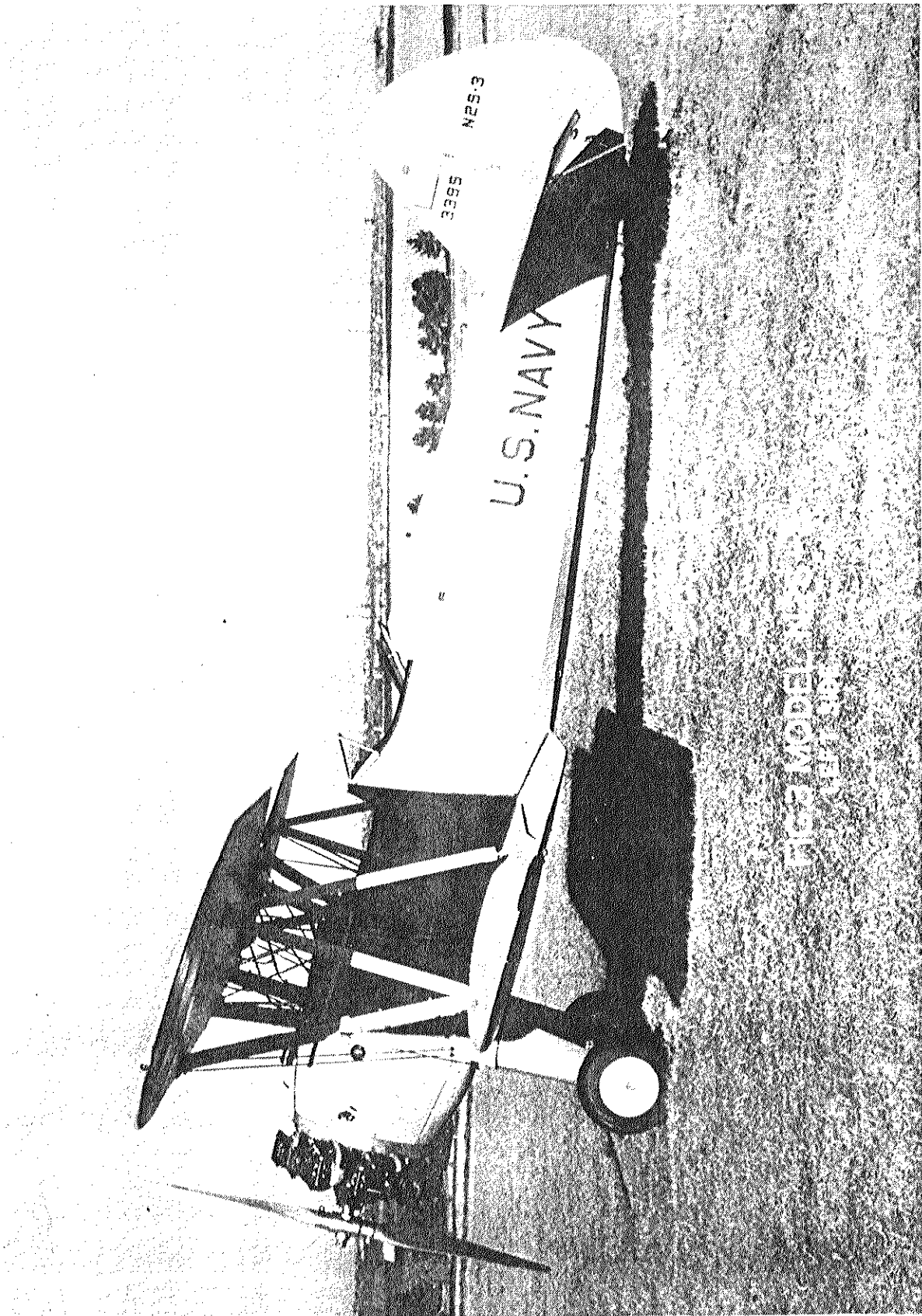

FIG. 1 MODEL  
AIRCRAFT

# STEARMAN AIRCRAFT

DIVISION





1927 MODEL N2S3  
U.S. NAVY

SECTION I

D - TABLE OF CHARACTERISTICS

	<u>N2S-1</u>	<u>N2S-2</u>	<u>N2S-3</u>
Normal Gross Weight (Lbs.)	2682.7	2755.8	2726.7
Fuel Capacity (Gallons)	46	46	46
Wing Area (Feet)	297.6	297.6	297.6
Wing Span - Upper (Feet)	32'2"	32'2"	32'2"
Wing Span - Lower (Feet)	31'2"	31'2"	31'2"
Rated Power of Engine (B.H.P.)	220	220	220
Rated Altitude	Sea Level	Sea Level	Sea Level
Wing Loading (Lbs./sq. ft.)	9.03	9.26	9.16
Power Loading (Lbs/B.H.P.)	12.19	12.53	12.39
High Speed at Sea Level (M.P.H.)	124	124	124
(Knots)	107.8	107.8	107.8
*Stalling Speed at Sea Level (M.P.H.)	53	54	54
(Knots)	46	46.9	46.9
Initial Rate of Climb (Ft/min.)	825	775	800
Service Ceiling (Feet)	13,300	12,800	13,000
Take-off Distance in Calm (Feet)	600	600	600
Cruising Speed (M.P.H.)	96	102	96
(Knots)	83.5	88.5	83.5
Endurance at Cruising Speed (Hours)	4	4	4
Range at Cruising Speed (Miles)	373	408	373
Endurance at High Speed (Hours)	2.20	2.20	2.20
Range at High Speed (Miles)	272.8	272.8	272.8

\* With 50% Fuel and Oil Consumed.



## SECTION II

### COCKPIT ARRANGEMENT AND CONTROLS

#### A. COCKPIT ARRANGEMENT

The arrangement of the cockpits are shown on pages

#### B. FLYING CONTROLS

##### 1. GENERAL:

The flight control arrangement of the Models N2S-1, N2S-2 and N2S-3 are identical. They are of the stick and hinged rudder pedal type. A complete set of flight controls are installed in each cockpit.

##### 2. CENTRAL CONTROL:

The elevator control system consists of a stick in each cockpit mounted on a large diameter chrome molybdenum steel torque tube, supported at the front and rear by self-aligning ball bearings in housings bolted to the bottom fuselage truss. The control stick sockets are aluminum alloy forgings. The control sticks are constructed of swaged aluminum alloy tubing and are provided with rubber handgrips.

##### 3. ELEVATOR CONTROL:

The elevator control consists of a system of push-pull tubes interconnecting front and rear sticks, the bottom of the rear stick socket to a ball bearing idler, located about midway back in the fuselage, and the idler to the single horn bolted between the ends of the elevator torque tubes. All push-pull tubes are provided with ball bearing ends.

##### 4. AILERON CONTROL:

The aileron controls system consists of push-pull tubes which are attached at the inboard end to a control horn bolted to the stick torque tube and extending outboard into the lower wings to an idler, and then to the aileron bellcrank located at

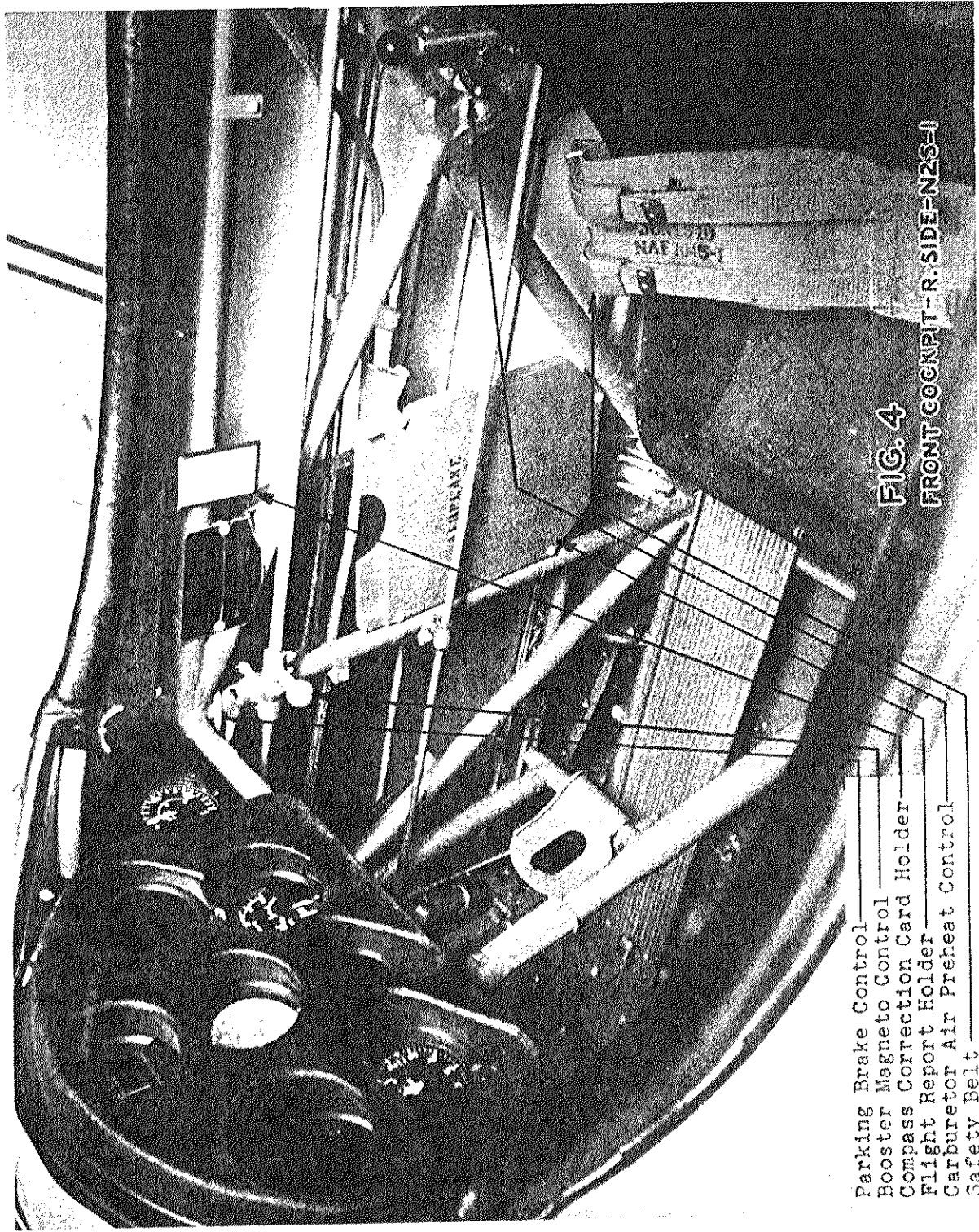

- Parking Brake Control
- Booster Magneto Control
- Compass Correction Card Holder
- Flight Report Holder
- Carburetor Air Preheat Control
- Safety Belt

FIG. 4  
FRONT COCKPIT - R. SIDE-N26-1

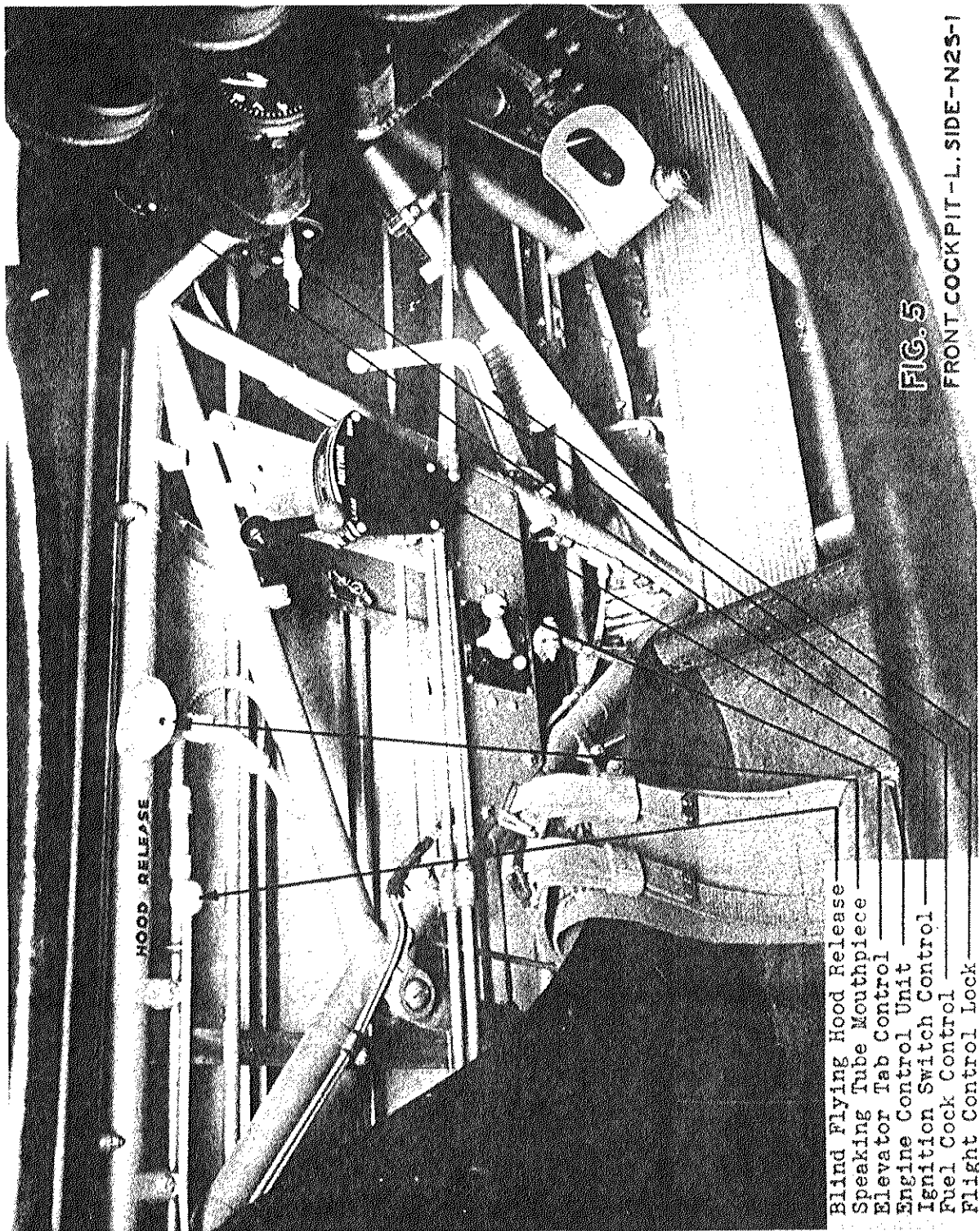

- Blind Flying Hood Release
- Speaking Tube Mouthpiece
- Elevator Tab Control
- Engine Control Unit
- Ignition Switch Control
- Fuel Cock Control
- Flight Control Lock

FIG. 5  
FRONT COCKPIT--L. SIDE--N2S-1



FIG. 6

REAR COCKPIT - RSIDE - N2S - 1

- Booster Magneto Control
- Parking Brake Control
- Compass Correction Card Holder
- Starting Crank
- Safety Belt

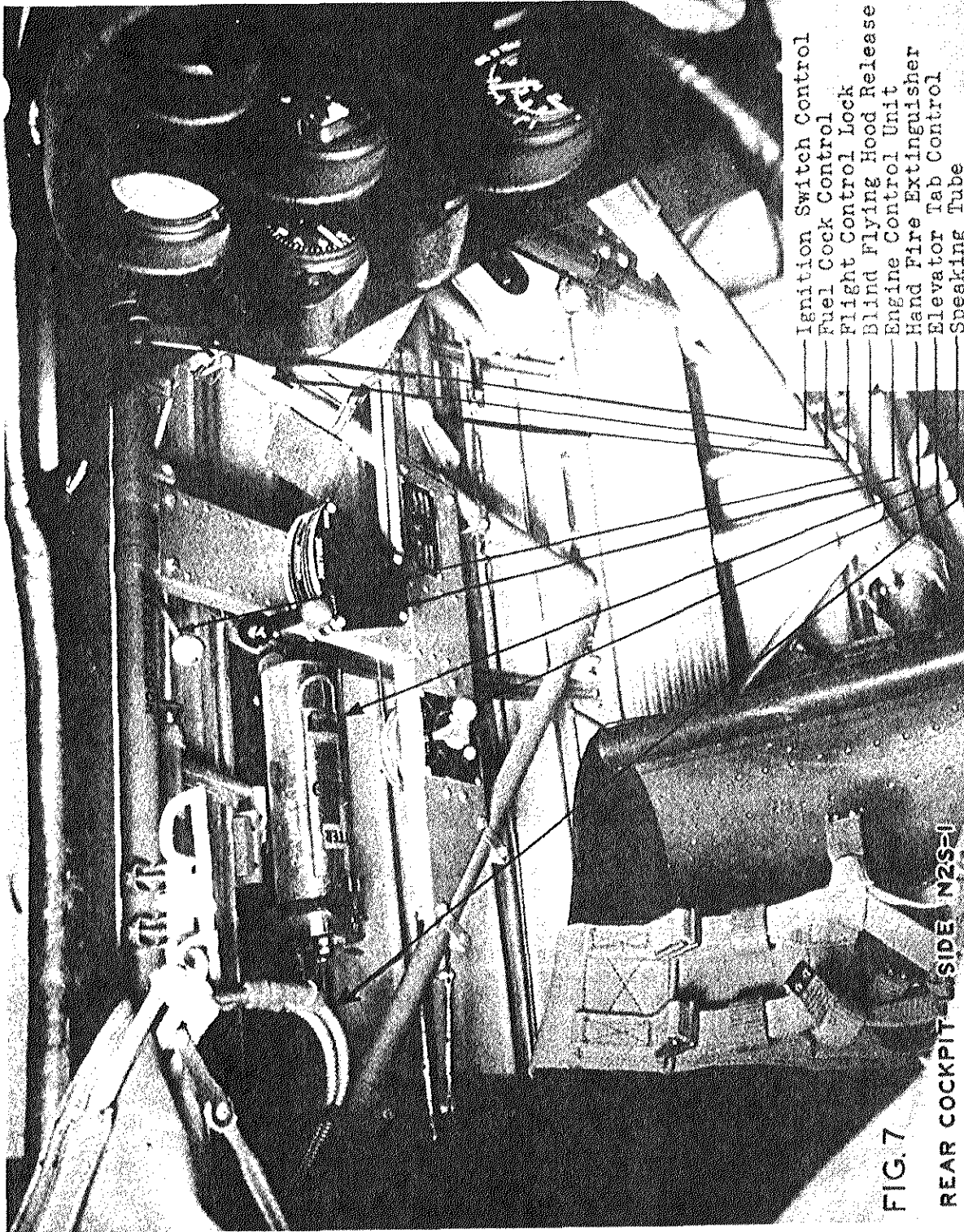

- Ignition Switch Control
- Fuel Cock Control
- Flight Control Lock
- Blind Flying Hood Release
- Engine Control Unit
- Hand Fire Extinguisher
- Elevator Tab Control
- Speaking Tube

FIG. 7

REAR COCKPIT - SIDE N2S-11

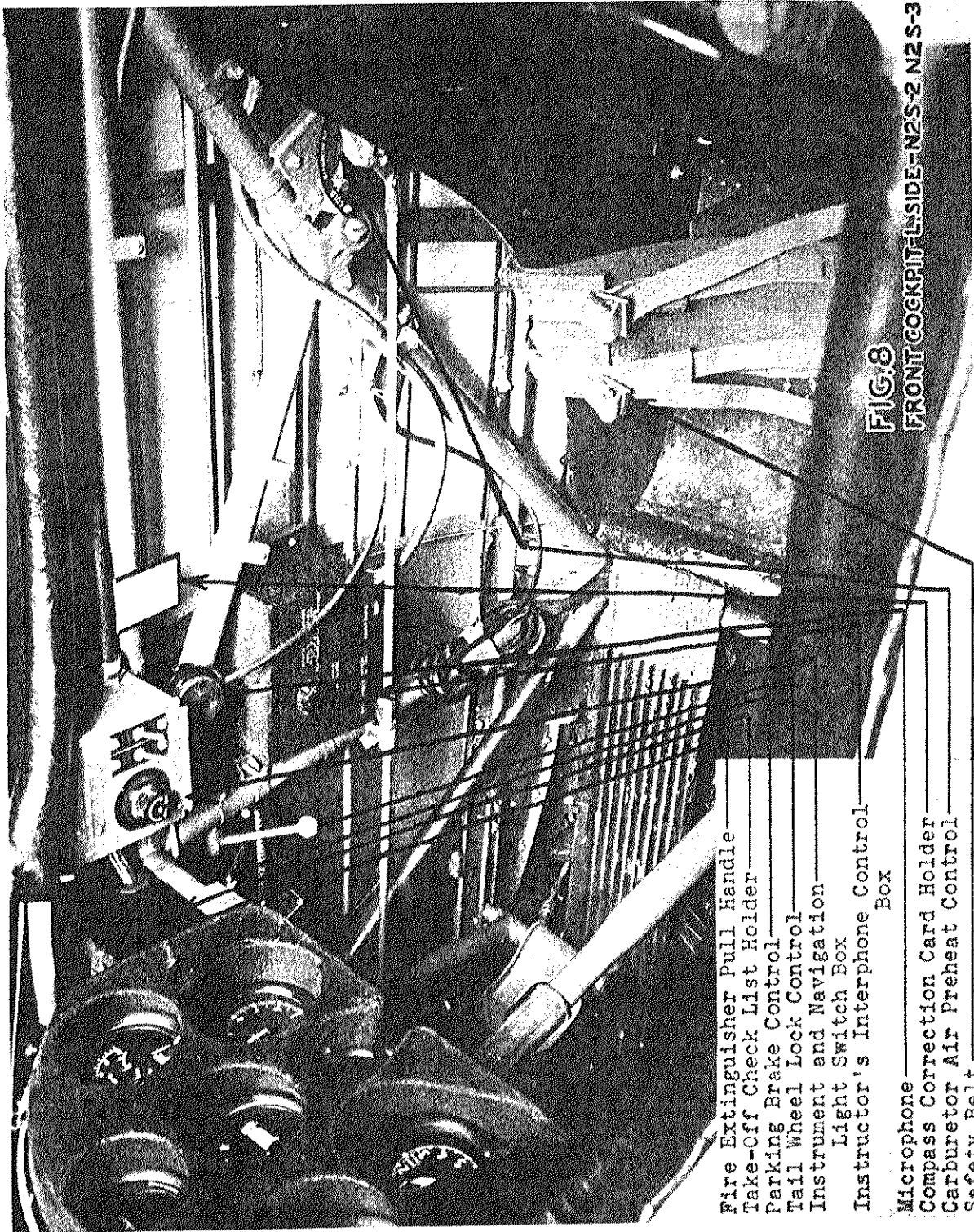

- Fire Extinguisher Pull Handle
- Take-Off Check List Holder
- Parking Brake Control
- Tail Wheel Lock Control
- Instrument and Navigation Light Switch Box
- Instructor's Interphone Control Box
- Microphone
- Compass Correction Card Holder
- Carburetor Air Preheat Control
- Safety Belt

FIG. 8  
FRONT COCKPIT-LSIDE-N2S-2 N2S-3

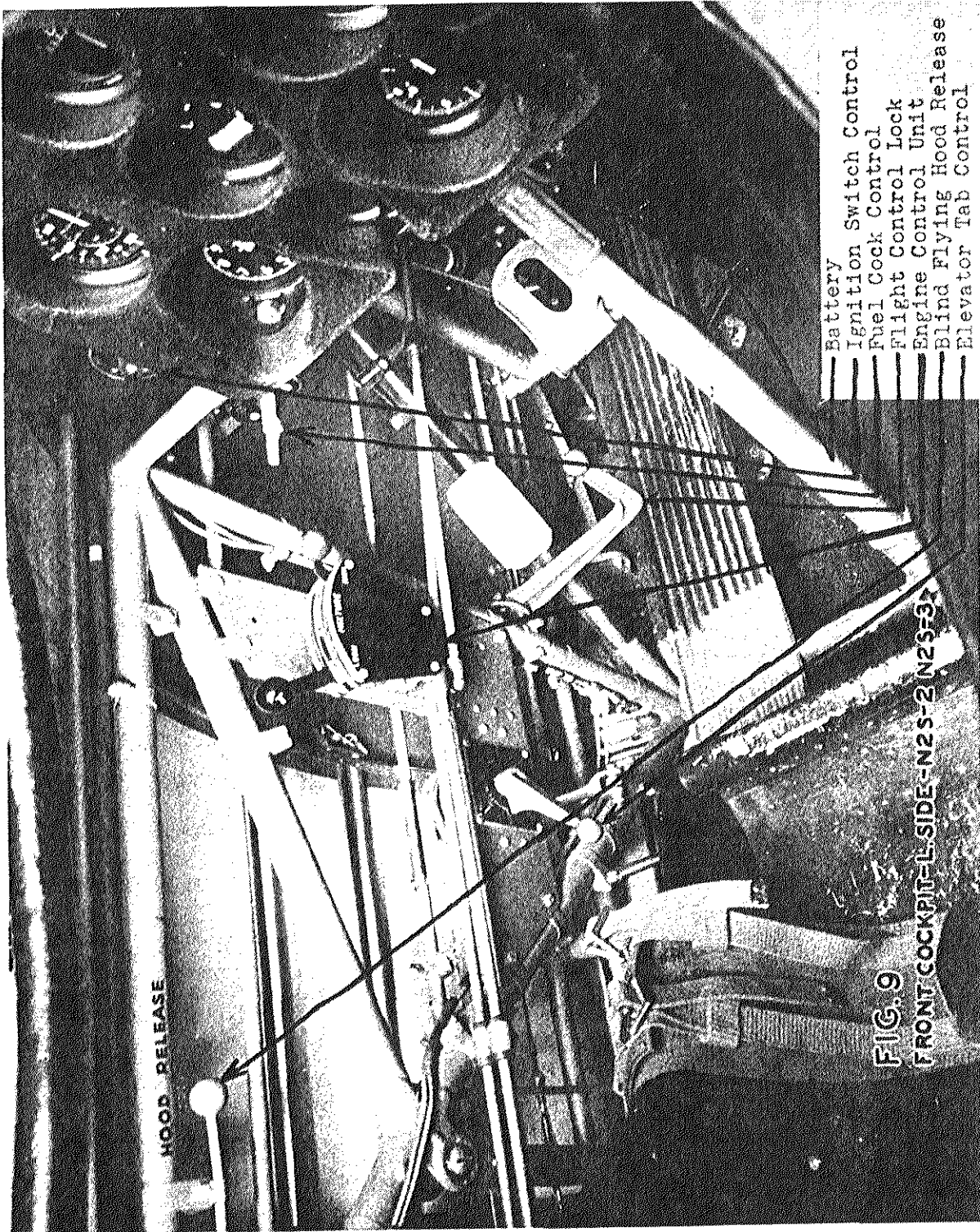

- Battery Switch Control
- Ignition Switch Control
- Fuel Cock Control
- Flight Control Lock
- Engine Control Unit
- Blind Flying Hood Release
- Elevator Tab Control

FIG. 9  
FRONT COCKPIT-L SIDE-N2S-2 N2S-32

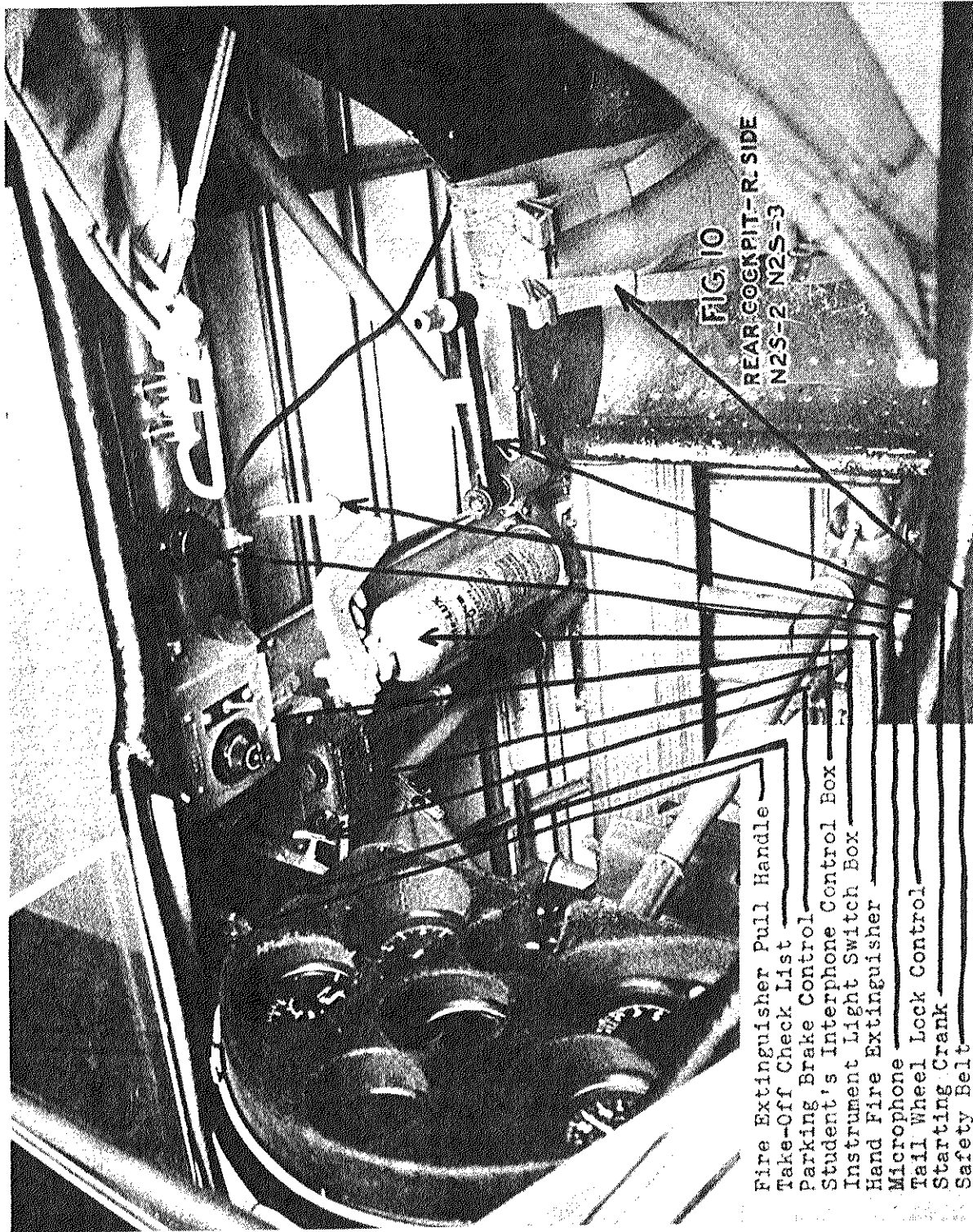
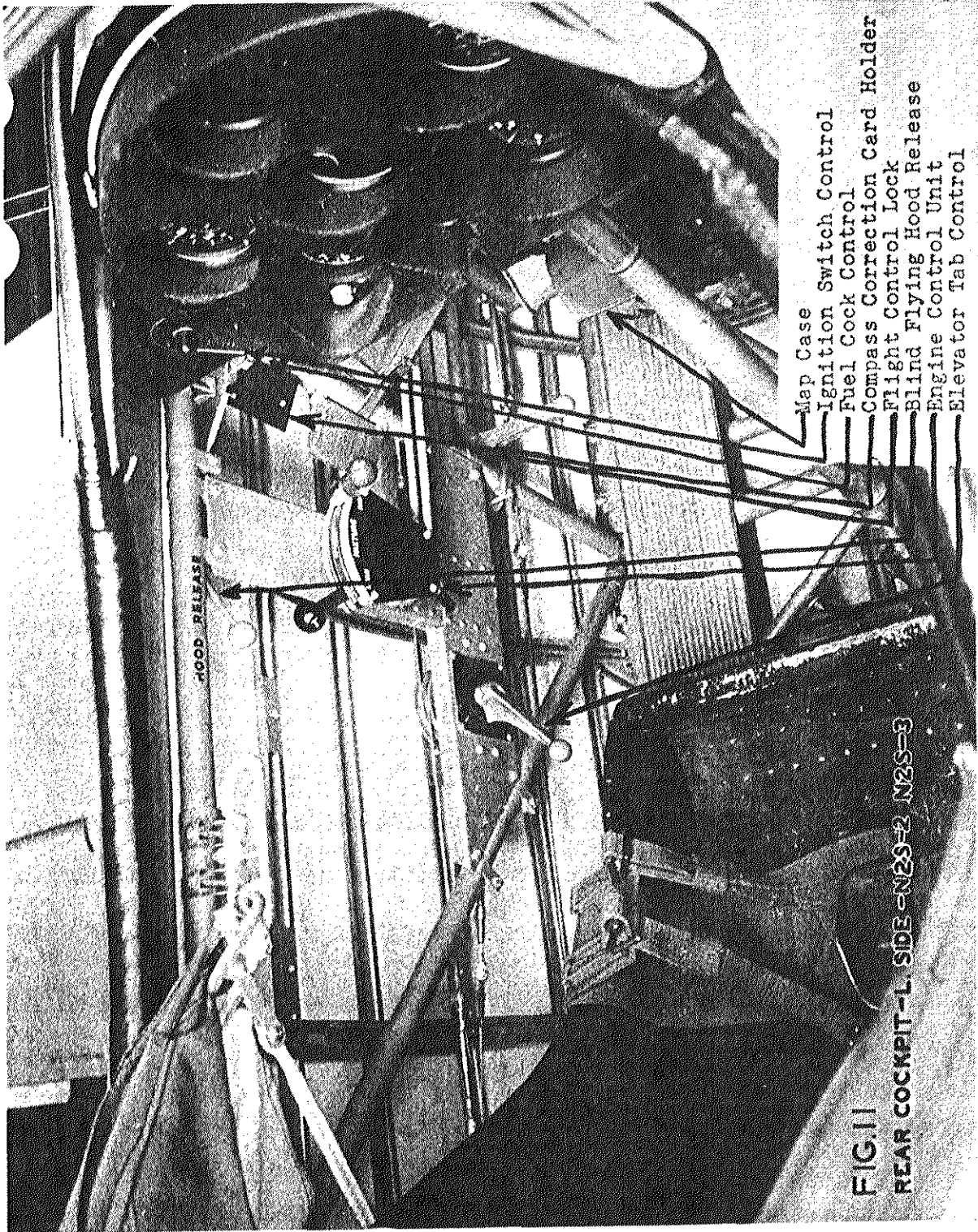

FIG. 10  
REAR COCKPIT - R. SIDE  
N2S-2 N2S-3

- Fire Extinguisher Pull Handle
- Take-Off Check List
- Parking Brake Control
- Student's Interphone Control Box
- Instrument Light Switch Box
- Hand Fire Extinguisher
- Microphone
- Tail Wheel Lock Control
- Starting Crank
- Safety Belt





the aileron semi-span. A short link connects the aileron bell-crank to the aileron mast. All moving parts in the aileron control system are provided with ball bearing hubs and ends. The controls to the right and left are entirely independent.

#### 5. RUDDER CONTROL:

The rudder pedal system consists of "L" shaped tubular hangers, supported above the pedal by ball bearings, cast aluminum alloy brake pads, aluminum alloy tubes interconnecting the front and rear rudder pedals, and a continuous cable system connecting to the rudder.

#### 6. ELEVATOR TRIM TAB:

Horizontal trim of the airplane is effected by trimming tabs located in the trailing edge of the elevators. These tabs are cable operated by an irreversible mechanism located near the front spar of the stabilizer. This irreversible mechanism is driven by cast aluminum alloy control handles, located at the left side of front and rear cockpits, which require a total movement of  $270^{\circ}$  to obtain the full tab range of  $15^{\circ}$  up and  $15^{\circ}$  down. The trim tab system is sufficiently powerful to trim the airplane in all normal conditions of speed and load.

### C. POWER PLANT CONTROLS:

NOTE: The power plant controls for the Models N2S-1, N2S-2 and N2S-3 are nearly identical and all differences will be listed.

#### 1. THROTTLE UNIT:

The Air Corps Type B-13 throttle control unit is provided in the front cockpit of the N2S-1, N2S-2 and N2S-3 and in the rear cockpit of the N2S-1. This unit has levers for both throttle control and mixture control. In the rear cockpit of the N2S-2 and N2S-3, a modified B-13 throttle control unit is provided. This unit is identical to the B-13 with the exception of a mixture control lock that has been incorporated in the unit.

#### 2. FUEL COCK CONTROL:

Flow of fuel from the tank to the engine is controlled by handles operating the fuel shut off valve. The handles are

located in both cockpits on the left side of the airplane just below the instrument panel in a position easily seen and accessible by the pilot. The dial provided with the handle is marked "On" and "Off".

3. PREHEATER CONTROL:

The preheater control is located between the front and rear cockpit on the right side of the airplane. It is accessible from the front or rear cockpit. The preheater controls are of the rod and bellcrank type. The handle is moved forward for cold air and aft for hot air. Intermediate positions produce mixtures of hot and cold air.

4. BOOSTER MAGNETO CONTROL:

(Model N2S-1 only) The booster magneto is operated by knobs attached to a push-pull tube running through both cockpits at the right side and connected to a cable and shock absorber cord assembly. The cable operates a drum on the magneto shaft through a system of pulleys. The shock absorber cord, to which the end of the cable is anchored, returns the controls to their original position after the pull.

NOTE: The Model N2S-2 and N2S-3 starters have integral magnetos and do not require a control in the cockpit.

5. IGNITION SWITCH CONTROL:

The ignition switch control is located on the left side of the instrument board in both cockpits. These controls are mechanically interconnected by levers and shafts to the Type A-7 ignition switch in the engine section.

6. ENGINE PRIMER:

The primer is located on the starter panel in the left side engine cowling.

7. STARTER CLUTCH CONTROL:

The starter clutch control is located on the starter panel in the left side of the engine cowling.

## D. AUXILIARY CONTROLS

### 1. BRAKE PEDALS:

Both front and rear rudder pedals carry cast aluminum alloy brake pads. The front and rear brake pedals of each side are interconnected by a series of rods and bellcranks. The brake control master cylinder is supported ahead of the front rudder pedals and is controlled by the forward bellcrank located at the centerline of the pedal hanger support.

### 2. RUDDER PEDAL ADJUSTMENT:

The front and rear rudder pedals are provided with toe-operated latch adjustment to enable the crew to select in flight or on the ground any one of the four positions thus provided to compensate for the difference in stature or flying requirements.

### 3. PARKING BRAKE:

A small pull handle conveniently located on the left side of each cockpit, is provided for the control of the parking valve. The brakes may be locked for parking in the open by pulling this handle out and applying firm pressure to both brake pedals. The brakes may be released by the application of further pressure to the pedals without touching the control handle.

### 4. SEAT ADJUSTMENT:

Both seats are of the type which, being supported to the tubes by clamp bearings, are vertically adjustable for a distance of 5" in increments of 1/2". This enables both members of the crew to adjust their position for stature and comfort in formation flying and training problems. The seats are arranged so that a portion of the occupant's weight is balanced by means of a shock cord loop, thus assisting him in effecting adjustment.

### 5. FIRE EXTINGUISHER:

The Model N2S-1 is provided with a hand fire extinguisher Type A-2. It is located in a door in the fuselage left side fairing at the rear cockpit. It is accessible from the student's cockpit and by pulling a quick-acting latch is also accessible from the outside.

The Models N2S-2 and N2S-3 are provided with a hand CO<sub>2</sub> pressure fire extinguisher. It is located on the right side of the rear cockpit just forward of the seat.

The Models N2S-2 and N2S-3 are also provided with a fixed CO<sub>2</sub> pressure fire extinguisher system for the engine compartment. The controls for this system are located on the right side of the instrument base panel in both cockpits.

#### 6. TAIL WHEEL CONTROLS:

(N2S-1 only) The tail wheel controls are connected to the rudder control system. The tail wheel steering controls disengage from the rudder control system when the tail wheel swivels thru an angle greater than the maximum rudder angle.

NOTE: The Models N2S-2 and N2S-3 have lockable tail wheels and not steerable.

#### 7. TAIL WHEEL LOCK:

(N2S-2 and N2S-3 only) A spring attached to a lock plunger normally keeps the tail wheel in the locked position. To release the tail wheel, place the tail wheel lock control handle in the up position. The control handle is located on the right side of both cockpits just forward of the seat. To lock tail wheel, place control handle in the down position. If the control handle is placed in the locked position while taxiing in a turn, the lock will not engage till the airplane is held straight, permitting the tail wheel to line up. During all taxiing the tail wheel shall be free. It shall be locked only before take-off.

#### 8. ELECTRICAL CONTROLS:

(N2S-2 and N2S-3 only) The switch boxes which contain the switches and rheostats for the control of the electrical equipment are located on the right side just aft the instrument base panel in both cockpits. All fuses are located within the switch box.

#### 9. BLIND FLYING HOOD:

A blind flying hood, to be used in training for instrument flying, is installed in the rear cockpit. A brass wire loop attached to the front flying hood bow snaps into place above the instrument panel. To close the hood assembly a release

knob is provided in each cockpit located below the upper left longeron. The words "Hood Release" are stenciled on the longeron above the release knob.

## SECTION III

### POWER PLANT OPERATION

#### A. GENERAL DATA

##### 1. Model N2S-1

Engine	Continental R-670-4
Gear Ratio	1 : 1
Fuel	73 Octane

##### 2. Model N2S-2

Engine	Lycoming R-680-8
Gear Ratio	1 : 1
Fuel	73 Octane

##### 3. Model N2S-3

Engine	Continental R-670-4
Gear Ratio	1 : 1
Fuel	73 Octane

#### B. RATING

##### 1. Model N2S-1

Normal	220 B.H.P. at 2075 R.P.M. at Sea Level
--------	--

##### 2. Model N2S-2

Normal	220 B.H.P. at 2100 R.P.M. at Sea Level
--------	--

##### 3. Model N2S-3

Normal	220 B.H.P. at 2075 R.P.M. at Sea Level
--------	--

### C. STARTING

1. Ignition Switch "Off"
2. Pull propeller through several times to make certain that combustion chambers are free of excess oil.
3. Fuel Cock Control "On".
4. Carburetor Air Control - Full "Cold" position.
5. Mixture Control - Full "Rich" position.
6. Throttle Setting - (Approx. 1/2 inch open).
7. Primer - 2 to 4 full strokes. Shut off when engine picks up on carburetor.
8. Starter - Energize the inertia starter with hand crank.
9. Ignition Switch "On".
10. Engage Starter-Pull starter clutch control located on the starter panel in the left side of the engine cowling.
11. Booster Magneto - (N2S-1 only) Pull booster magneto control knob to the rear and release while the starter is turning the engine over, repeat till engine starts.

### D. WARM-UP

1. When the engine starts, set throttle to obtain 500 to 700 R.P.M.
2. CAUTION: If oil pressure gage does not register within one (1) minute, stop engine.
3. Set throttle 700 R.P.M. for warm-up.
4. Oil temperature 20° C.

### E. STOPPING ENGINE

1. Idle engine to approximately 500 R.P.M.
2. Fuel Cock Control "Off" position.
3. Ignition switch "Off" position.



4. Slowly open throttle till engine stops.

F. MIXTURE CONTROL

1. During the take-off, climbs at or near maximum rate and high speed level flight below 3000' altitude, the mixture control shall be maintained in the "FULL RICH" position. For all operations above 3000' altitude, except cruising altitude, the mixture may be leaned only sufficiently to maintain smooth engine operation. For cruising operations below 70% normal rated power, the mixture control may be leaned to give a drop of 20 R.P.M. For landings, mixture control "FULL RICH" position.

G. FUEL

73 Octane Army-Navy Specification AN-9527

H. OIL

1. Army-Navy Specification AN-9532 Grade 1100

2. Temperature - 50 to 70° C.

	<u>N2S-1</u>	<u>N2S-2</u>	<u>N2S-3</u>
3. Pressure - Maximum	90 Lbs.	80	90
Desired	70-90	50-75	70-90
Min. Cruising	60 Lbs.	35	60
Min. Idling	15 Lbs.	15	15

I. OVERSPEED

Maximum permissible R.P.M. during dives is:

N2S-1 - 2490

N2S-2 - 2520

N2S-3 - 2490

J. FUEL SYSTEM

The fuel system consists of a single gravity tank containing the entire fuel supply, 46 gallons, located in the Center Section.

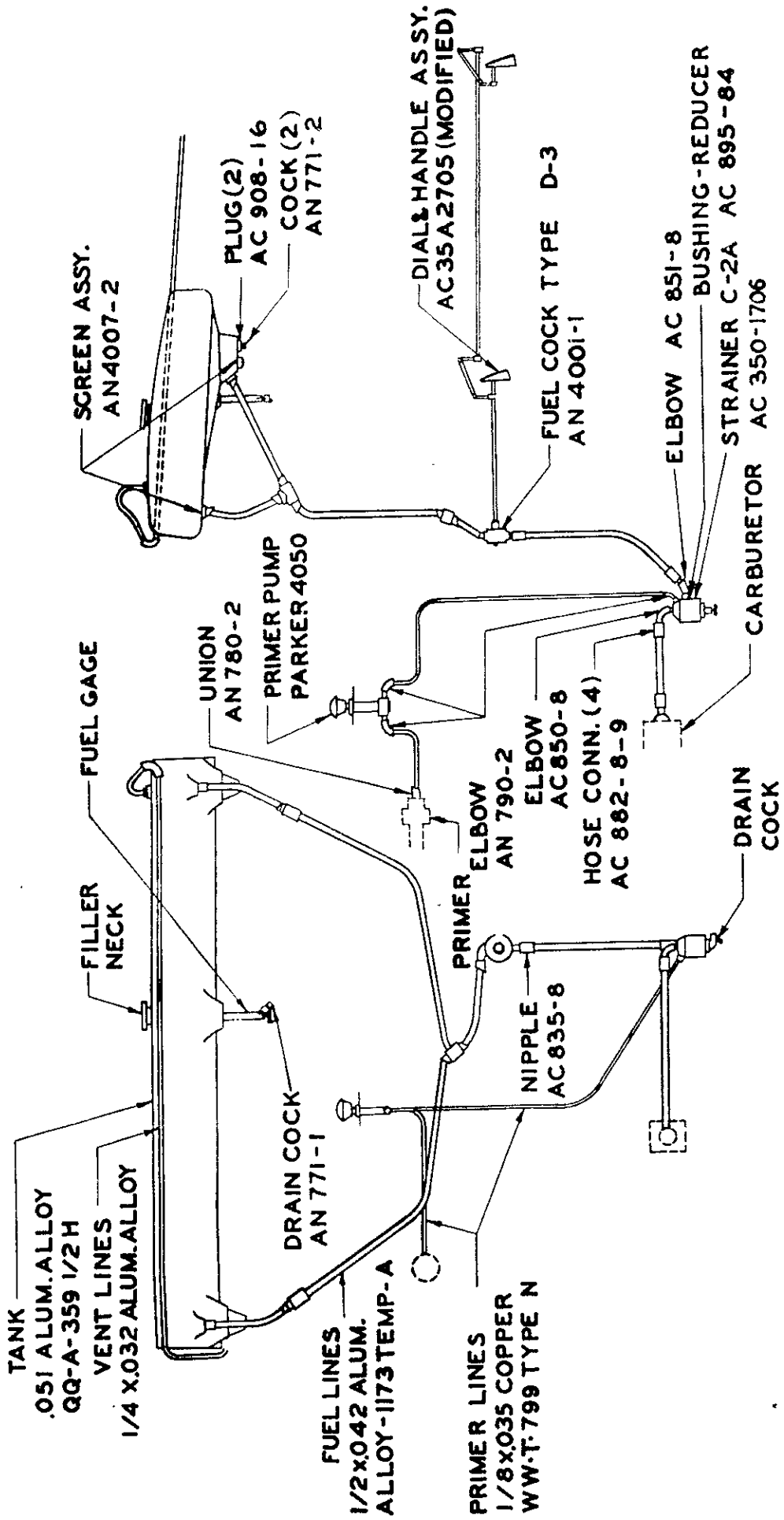

ALL FITTINGS ARE AC-811  
EXCEPT AS NOTED.

**FIG. 12 FUEL SYSTEM DIAGRAM**

MODELS: N2S-1 N2S-2 N2S-3

The tank used for the Models N2S-2 and N2S-3 incorporate the use of an NAF 1025-1 filler unit. The tank used for the Model N2S-1 incorporates the use of an Air Corps Type 39B4232 cap and adapter assembly. A sight type fuel gage is located at the bottom of the tank and is visible from either cockpit. A drain cock has been provided in the bottom of the fuel gage to permit draining the water or sediment that may collect. An Air Corps Type D-3 fuel cock is used to control the flow of fuel from the tank to the engine. The fuel cock control is operated by handles located in both cockpits on the left side of the airplane just below the instrument panel.

Normal fuel pressure desired - 1-1/2 to 2 lbs. (No adjustment of fuel pressure is possible with the gravity system.)

#### K. OIL SYSTEM

The oil systems for the Models N2S-1, N2S-2 and N2S-3 are very similar. The detailed sketches of each system are shown on pages 27, 28 and 29.

N2S-1: The oil tank for the Model N2S-1 is of welded 3S aluminum alloy construction, with the total volume of 5.8 U. S. gallons. However, only 4.4 U. S. gallons is the specified capacity required for the airplane. The remaining space cannot be filled due to the location of the filler neck. This tank incorporates the use of an Air Corps Type 39B4232 filler neck and cap assembly.

N2S-2, -3: The oil tanks used for the Model N2S-2 and N2S-3 are also of welded 3S aluminum alloy construction, with a total volume of 5.8 U. S. gallons and 4.4 U. S. gallons is the specified capacity required. However, these tanks incorporate the use of an NAF 1025-5 filler unit. This type of filler unit has an integral sounding rod, for the measurement of oil in the tank, and a screen for the straining of service oil. A short standpipe fitting has been installed at the oil outlet hole, in the bottom of the tank, to prevent sediment, which may collect in the bottom of the tank, from flowing into the engine. This fitting, however, can be removed and the tank flushed out.

The remainder of the oil systems for all three models are very similar as sketches on pages 27, 28 and 29 will indicate.

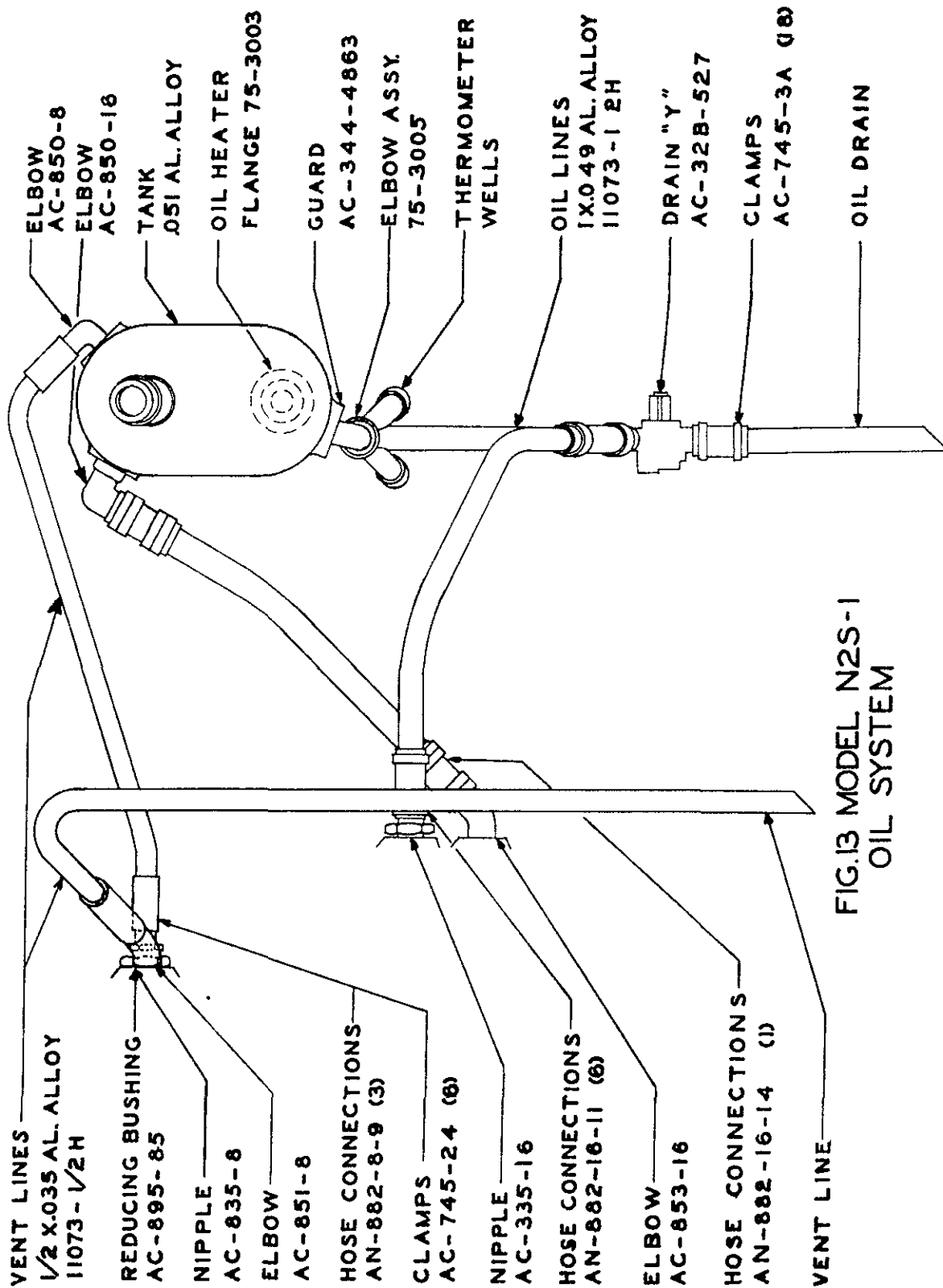

FIG.13 MODEL N2S-1  
OIL SYSTEM

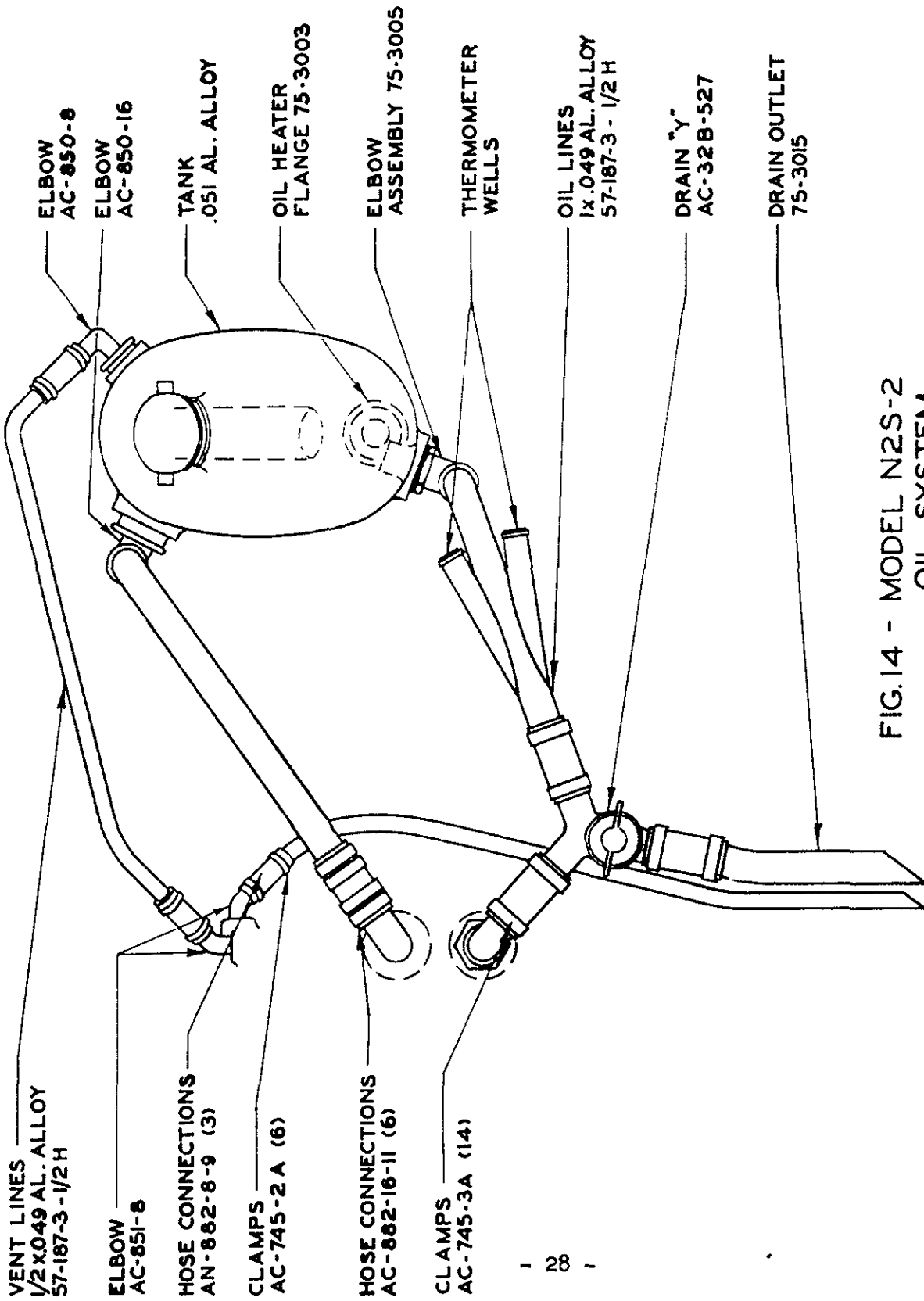

FIG.14 - MODEL N2S-2  
OIL SYSTEM

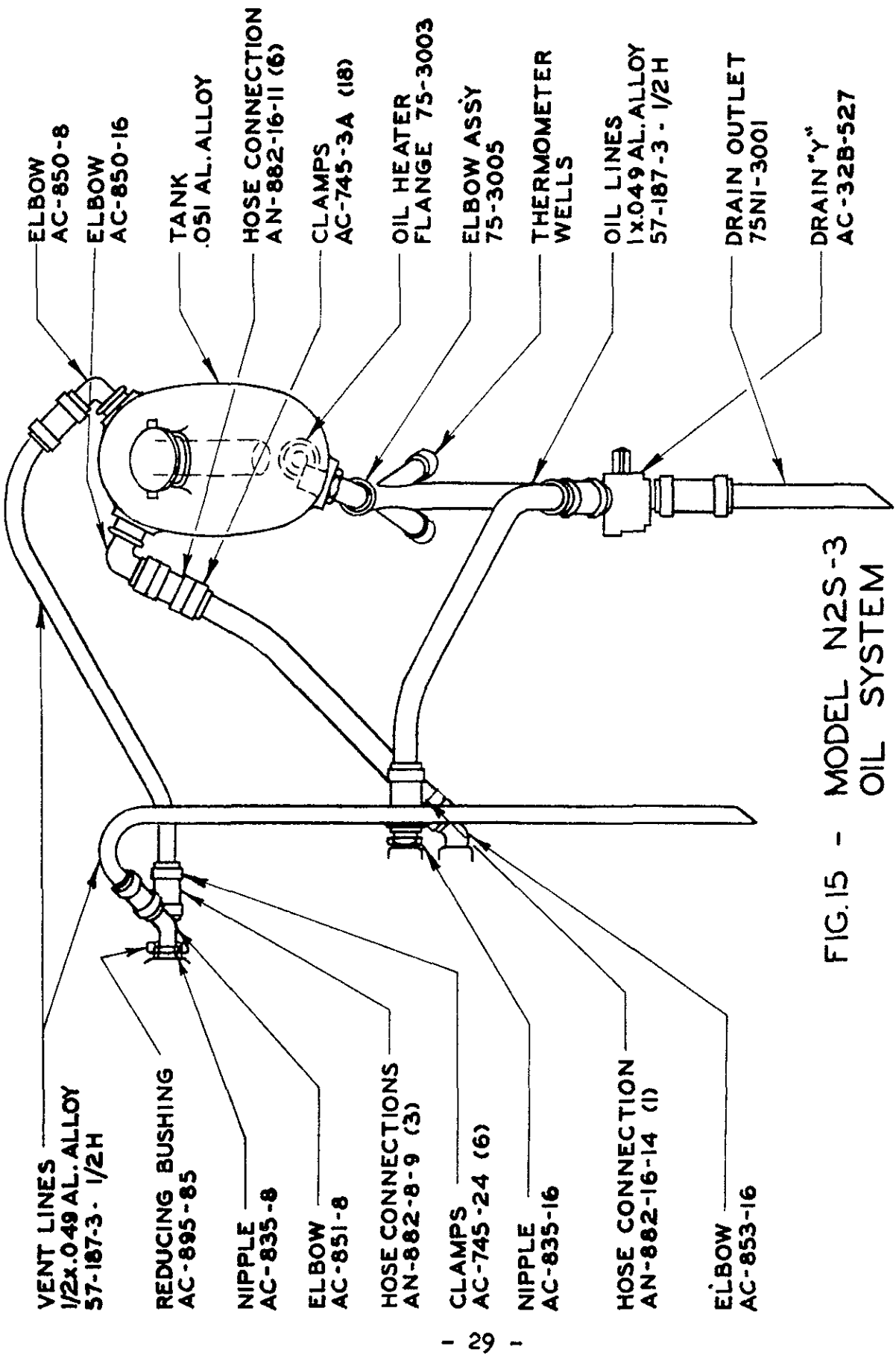

FIG.15 - MODEL N2S-3 OIL SYSTEM

#### L. CARBURETOR PREHEATER CONTROL

The air intake, for the Model N2S-2, consists of an aluminum alloy nose deflector cowling incorporating an air heater located behind the exhaust collector. The air heater consists of a hot air duct leading back to the carburetor and a cold air duct leading down through the engine section, and a cast magnesium carburetor air box bolted to the bottom of the carburetor. A cockpit control regulates two interconnected butterfly valves to furnish hot or cold air or a mixture of both to the carburetor.

The air intake system for the Models N2S-1 and N2S-3 consists of a top air intake duct extending through the cowl to the air mixing box at the carburetor and a hot air duct from the collector well to the air mixing box bolted to the bottom of the carburetor. A balanced valve controllable from the cockpit in the air mixing box provides hot or cold air or a mixture of both to the carburetor as required.

#### M. FUEL CONSUMPTION

##### MODELS N2S-1 and N2S-3

<u>Altitude</u>	<u>R.P.M.</u>	<u>Fuel Consumption (Gal./Hr.)</u>
Sea Level	1800	12.8
Sea Level	1850	13.6
Sea Level	1900	14.5
Sea Level	1950	15.8
Sea Level	2000	17.6
Sea Level	2075	20.8

MODEL N2S-2

<u>Altitude</u>	<u>R.P.M.</u>	<u>Fuel Consumption (Gal./Hr)</u>
Sea Level	1800	11.9
Sea Level	1850	13.1
Sea Level	1900	14.3
Sea Level	1950	15.7
Sea Level	2000	17.1
Sea Level	2050	18.6
Sea Level	2100	20.2



## SECTION IV

### NORMAL INSTRUMENT READINGS

As an example of normal instrument readings, the following might be expected under level flight cruising conditions:

	<u>N2S-1</u>	<u>N2S-2</u>	<u>N2S-3</u>
Altitude (Ft.)	2000	2000	2000
Propeller Pitch	Fixed	Fixed	Fixed
Indicated Airspeed (Knots)	76	83	76
R.P.M.	1750	1785	1750
Mixture	"FULL RICH"	"FULL RICH"	"FULL RICH"
Carburetor Preheat	Cold (Off)	Cold (Off)	Cold (Off)
Oil Pressure (Lbs/sq. in.)	70-80	70	70-80
Oil Temperature (°C)	60-70	50-60	60-70
Fuel Pressure	Gravity	Gravity	Gravity
Strut Temperature (°C)	15	15	15

SECTION V

FLYING CHARACTERISTICS

A. BALANCE

Longitudinal balance is maintained by the use of the elevator trim tab.

B. USEFUL LOAD

N2S-1:

Crew - (2 at 200 lbs. each) - - -	400 lbs.
Fuel - (46 gallons) - - - - -	276 lbs.
Oil - (4.4 gallons) - - - - -	<u>33 lbs.</u>
Total Useful Load	709 lbs.

N2S-2 and N2S-3:

Crew - (2 at 200 lbs. each) - - -	400 lbs.
Fuel - (46 gallons) - - - - -	276 lbs.
Oil - (4.4 gallons) - - - - -	33 lbs.
First Aid Kit - - - - -	<u>2.6 lbs.</u>
Total Useful Load	711.6 lbs.

C. TAKE-OFF - Models N2S-2 and N2S-3

In addition to the engine starting procedure the pilot should note the following check-off items which are on the check-off list located on the lower right side of the front and rear instrument panels:

1. Flight Controls - Unlocked (Up)
2. Tail Wheel - Locked (Down)
3. Elevator Trim Tab - Check Setting
4. Mixture Control - "Full Rich" (Forward)
5. Carburetor Air Preheat - "Cold" (Forward) (Except under icing conditions)

6. Altimeter, Clock, Compass, Airspeed, Turn and Bank:  
Check for operation and proper indication if installed.
7. Throttle: Ground R.P.M. should be approximately 1600  
Take-off on full throttle
8. Oil Pressure - N2S-2: 50-75      N2S-3: 70-90
9. Oil Temperature - Desired 20° C.

D. MANEUVERS

Maneuvers with this airplane shall be restricted to those permissible with this type of airplane. Under no circumstances should the maximum allowable engine R.P.M. be exceeded.

E. MANEUVERS PROHIBITED

Inverted Flight

Inverted Spins

Outside Loops

Snap Rolls at more than 106 MPH (92.1 knots), Indicated

Slow Rolls at more than 124 MPH (107.7 knots), Indicated

Do Not Exceed An Indicated Air Speed of 186 MPH  
(161.7 knots)

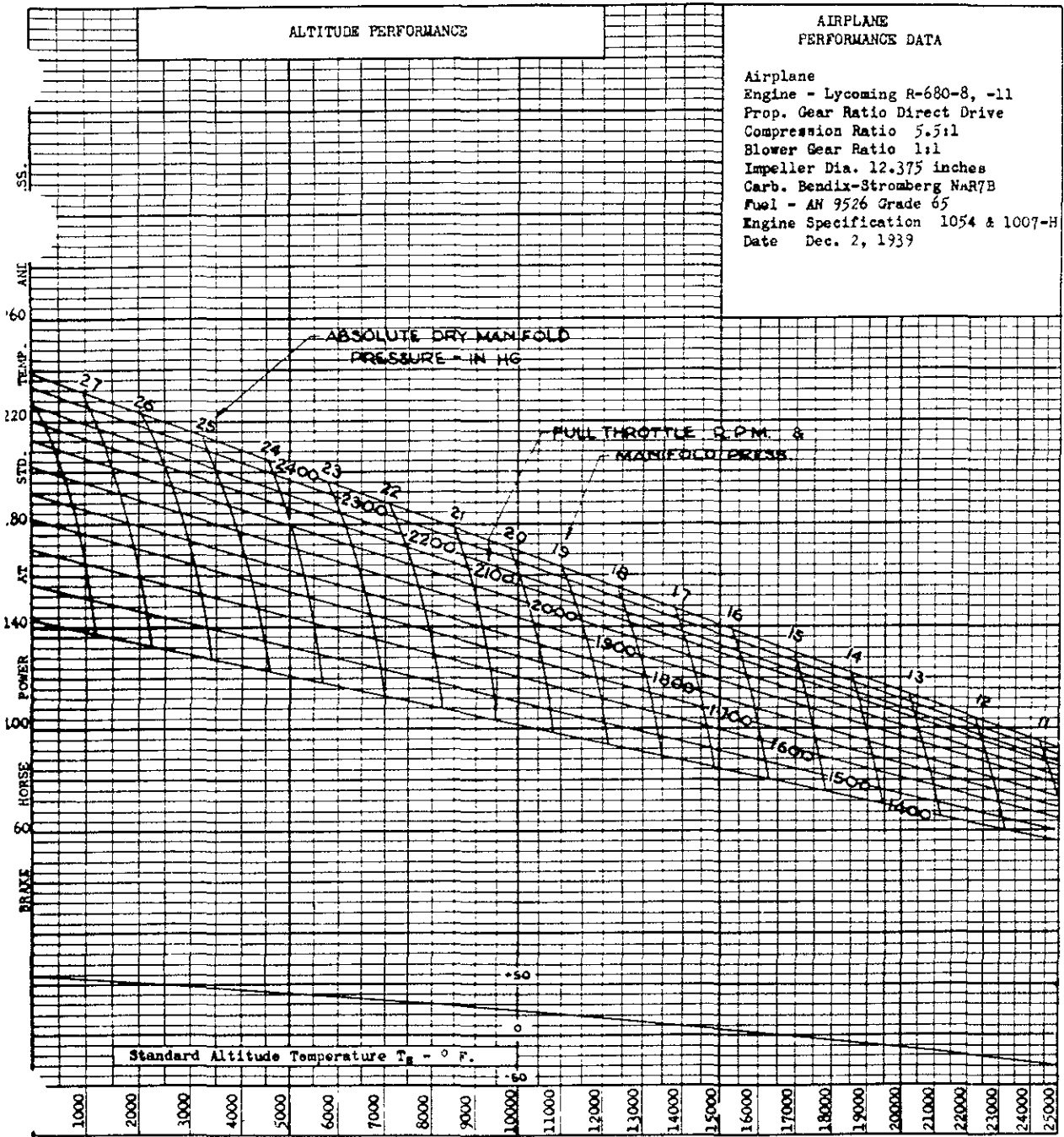

Figure 16  
PRESSURE ALTITUDE IN FEET  
- 36 -

TO FIND ACTUAL HORSEPOWER FROM ALTI-  
TUDE, RPM, MANIFOLD PRESSURE AND AIR  
INLET TEMP.

SEA LEVEL PERFORMANCE

1. Locate A on full throttle altitude curve for given RPM & manifold press
2. Locate B on sea level curve for RPM & manifold pressure & transfer to C.
3. Connect A & C by straight line & read horsepower at given altitude D.
4. Modify horsepower at D for variation of air inlet temperature T from standard altitude temperature  $T_s$  by formula

$$[\text{HP at D}] \times \sqrt{\frac{460 + T_s}{460 + T}} = \text{Actual HP}$$

[Approximately 1% correction for each 10° variation from  $T_s$ ]

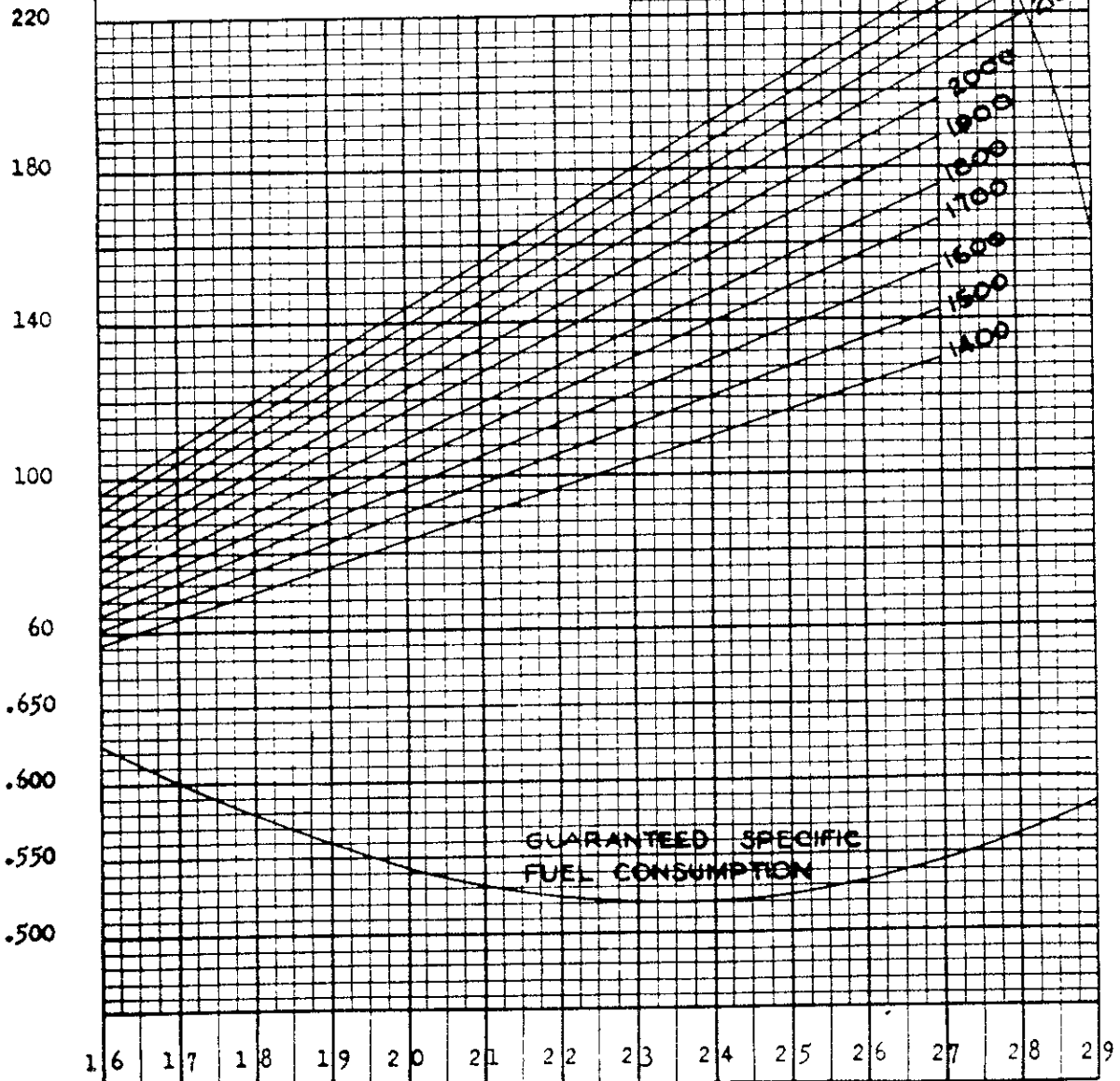

Figure 17  
ABSOLUTE MANIFOLD PRESSURE, IN. HG.

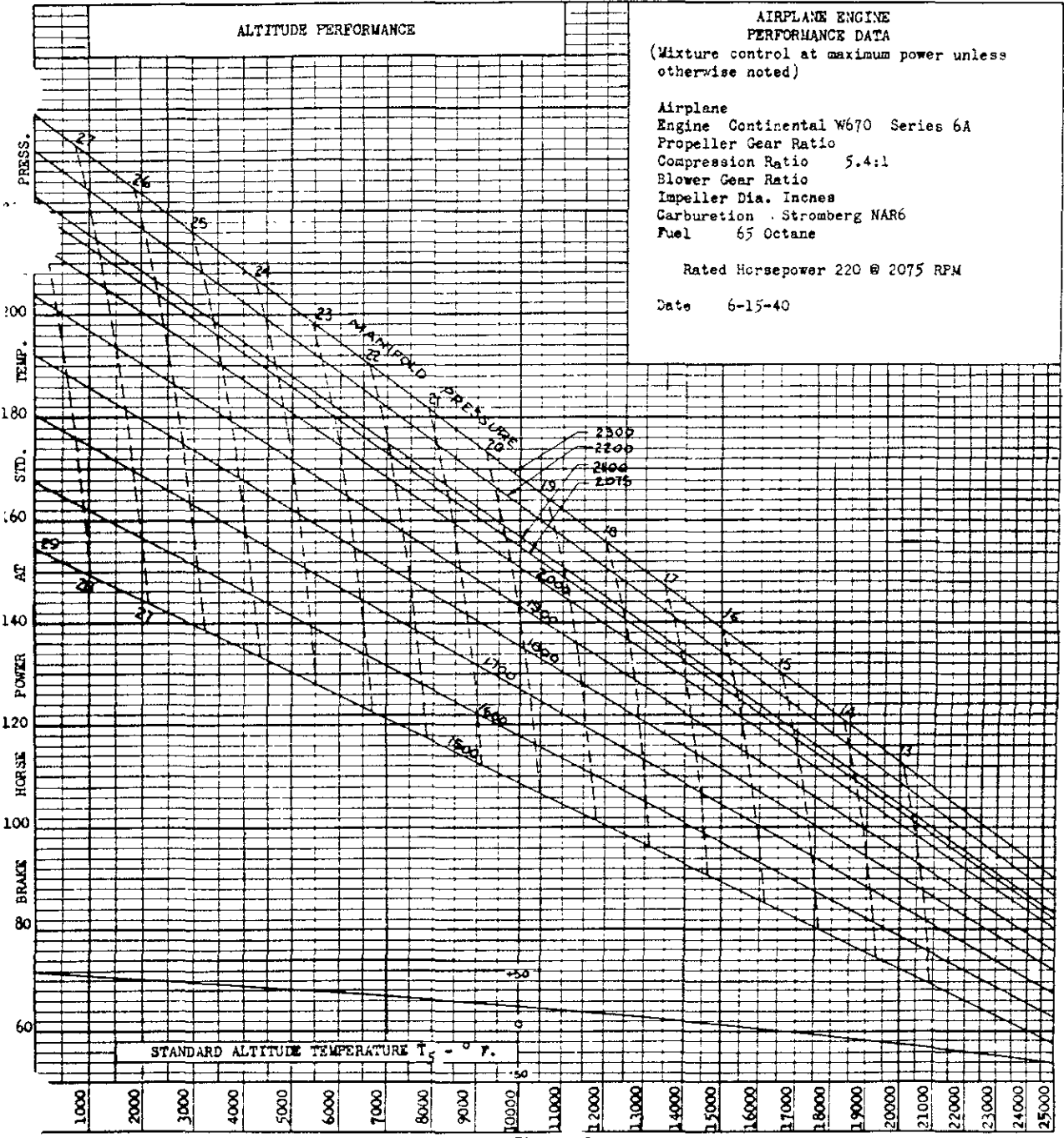

Figure 18  
 PRESSURE ALTITUDE IN FEET  
 - 38 -

TO FIND ACTUAL HORSEPOWER FROM ALTITUDE, R.P.M., MANIFOLD PRESSURE AND AIR INLET TEMP.

1. Locate A on full throttle altitude curve for given RPM and manifold press.
2. Locate B on sea level curve for RPM and Manifold pressure and transfer to C.
3. Connect A and C by straight line and read horsepower at given altitude D.
4. Modify horsepower at D for variation of air inlet temperature T from standard altitude temperature  $T_s$  by formula

$$[\text{HP at D}] \times \sqrt{\frac{460 + T_s}{460 + T}} = \text{Actual HP}$$

[Approximately 1% correction for each 10° F. variation from  $T_s$ ]

SEA LEVEL PERFORMANCE

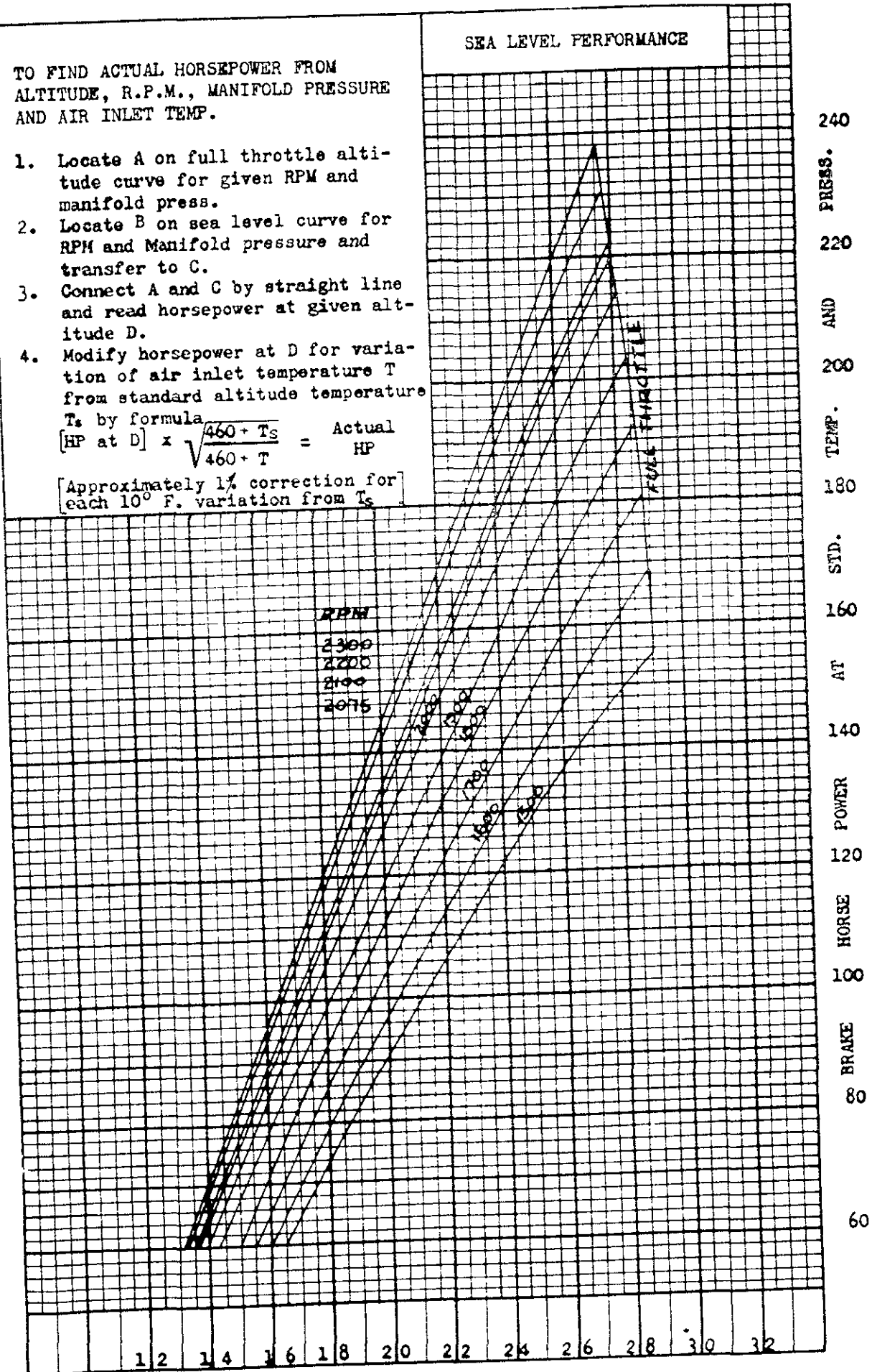

Figure 19

ABSOLUTE MANIFOLD PRESSURE, IN. HG.